

tomlinson®

Dual Food Warmers

Featuring...

- Quick heat-up
- Stainless steel construction
- Dual infinite temperature controls
- Compact design



Tomlinson® Dual Food Warmers

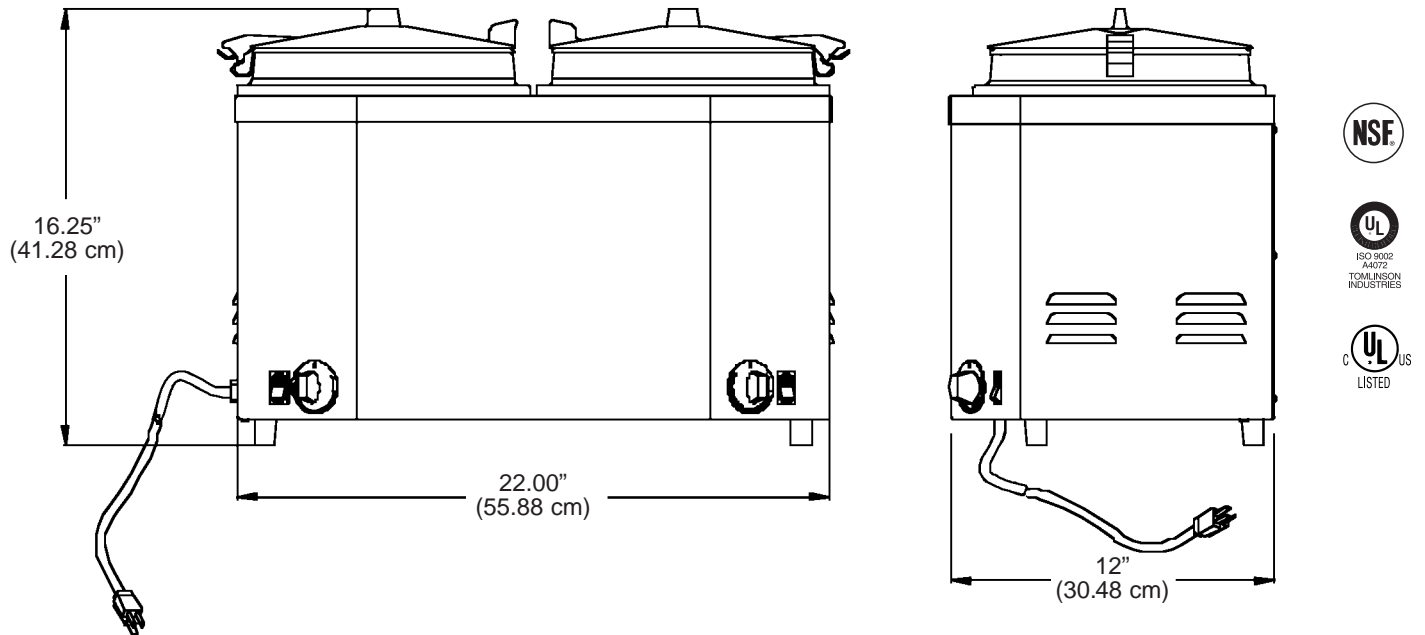

FEATURES:

- ✓ Available in 6, 8 or 12 quart (5.7 liter, 7.6 liter or 11.4 liter) capacities.
- ✓ 120 volt operation.
- ✓ Dual infinite temperature controls/switches.
- ✓ Fast heat-up with 550 watts per well.
- ✓ Easy to clean and maintain – stainless steel food insert and lid are dishwasher safe. The all stainless steel exterior can be wiped down with a soft cloth.
- ✓ Wet operation is recommended.
- ✓ Compact and designed to take up little counter space.
- ✓ Optional (recommended) transport assembly.

DIMENSIONS:

Height: 16.25" (41.28 cm), Width: 22" (55.88 cm), Depth: 12" (30.48 cm), Weight: 26 lbs. (11.8 kg)

MODEL NUMBER/DESCRIPTION:

#1015046	6 Qt. (5.7 liter)
#1014697	8 Qt. (7.6 liter)
#1014788	12 Qt. (11.4 liter)

ENERGY REQUIREMENTS:

120 Volts, 1100 Watts, 60 Hz., 10.83 Amps

tomlinson®

13700 Broadway Avenue
Cleveland, OH 44125-1992
Phone: 216/587-3400
800/945-4589 in the U.S. and Canada
FAX: 216/587-6192
800/945-9869 in the U.S. and Canada
www.tomlinsonind.com
World Class, Worldwide

DISTRIBUTED BY: