

SIMPLI-FLEX® 2100

STACKABLE CABINET CUP DISPENSERS

FIGURE 1

LOADING THE DISPENSER:

Your Modular SIMPLI-FLEX® cabinet dispenser is completely self-adjusting and can dispense virtually any size or shape of cup!

For reference to instructions below use exploded view of cabinet dispenser. (See figure 3)

1. Unwrap desired cups for dispenser.
2. Visually align cups with center of gasket and pusher. (See Figure 1 illustration A and B)
NOTE: bottom of cups to be facing out.
3. With one hand holding the back of the cabinet dispenser, push cups firmly into gasket until cups penetrate inside unit. (See Figure 1 illustration B and C)

STACKING CABINET DISPENSER:

Your Modular SIMPLI-FLEX® cabinet dispenser interlocks vertically by design for your convenience, leaving more counter space available for you!

1. Place one cabinet firmly on counter.
2. Position the bottom of second cabinet over the top of the first cabinet.
3. Lower into recess top of other cabinet until level and flush in all four corners.

CHANGING CUP SIZE:

For reference to instructions below use exploded view of cabinet dispenser. (See Figure 3)

1. Remove cups from cabinet dispenser. (See Figure 1 illustration C thru A)
2. Remove decorative clamp ring. (See Page 2 Figure 4 illustration A and B)
3. Peel off gasket from lip of dispenser tube. (See Page 2 Figure 4 illustration C and D)
NOTE: CAUTION when removing gasket, pusher may be under small amount of spring tension.
4. Replace gasket with desired size. (See Figure 2 Reference Chart)
5. Reassemble cabinet dispenser in reverse order. (See Page 2 Figure 4 illustration D thru A)

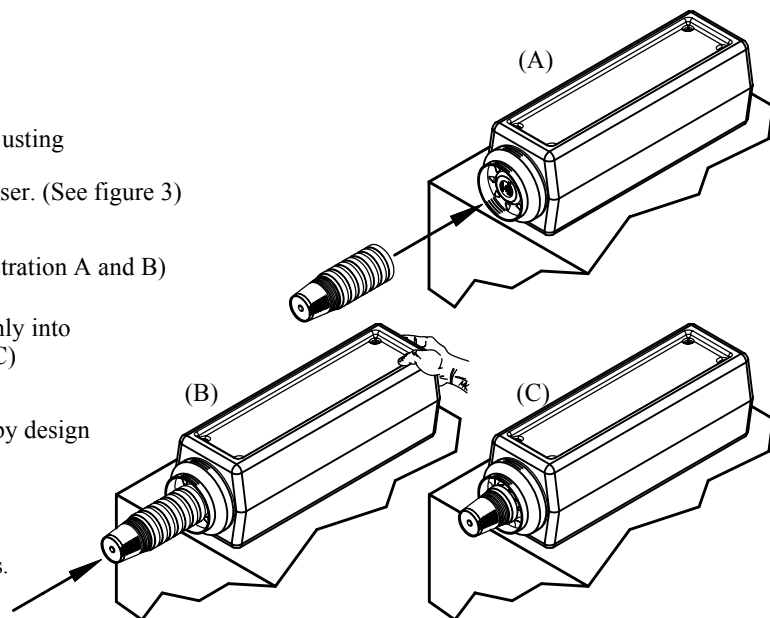

SIMPLI-FLEX 2100®

GASKET SIZE REFERENCE

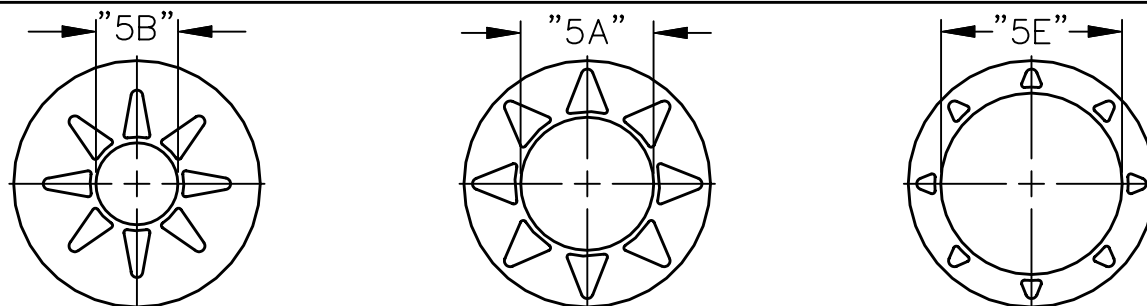

FIGURE 2

GASKET REFERENCE CHART

Dimension Letter:	"5B"	"5A"	"5E"
Cup Ounce:	3-1/2 oz. - 14 oz.	14 oz. - 32 oz.	32 oz. - 44 oz.
Cup Lip Diameter: (Metric)	2-1/4" - 3-7/8" (57mm - 98mm)	3-1/2" - 4-7/16" (89mm - 113mm)	4-1/4" - 4-5/8" (108mm - 117mm)

SIMPLI-FLEX 2100®

EXPLODED VIEW

No.	Description
1	Decorative clamp ring
2	Gasket(s)
3	Pusher
4	Spring
5	Screw(s)
6	Dispenser tube
7	Cabinet

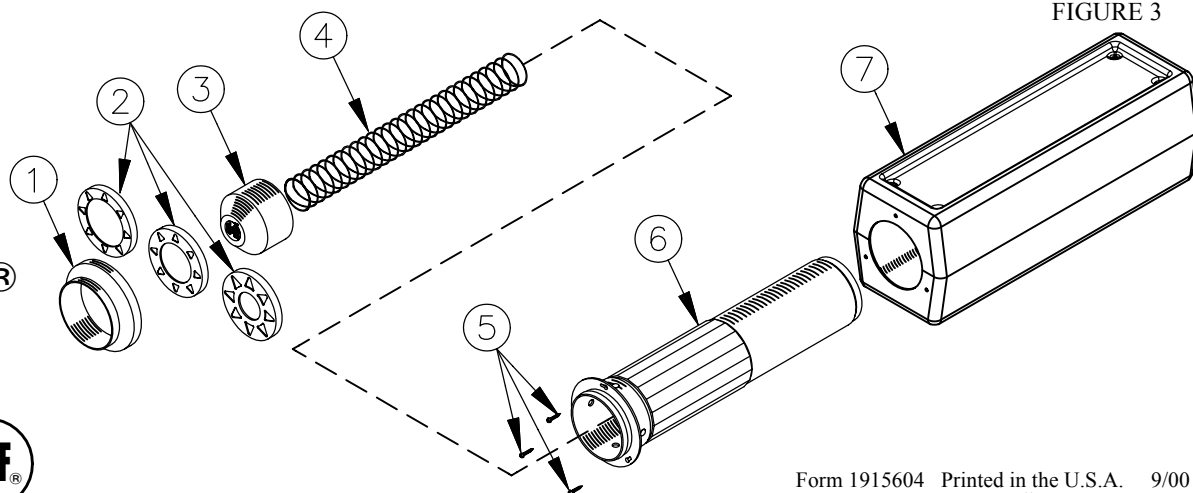

FIGURE 3

MODULAR®
DISPENSING SYSTEMS

DIVISION OF TOMLINSON INDUSTRIES

13700 Broadway Ave.
Cleveland Ohio 44125-1992
Phone: 216/587-3400

Fax: 216/587-0733
www.tomlinsonind.com

World Class, Worldwide
©Tomlinson Industries 1999



SIMPLI-FLEX® 2100

STACKABLE CABINET CUP DISPENSERS

CLEANING THE DISPENSER:

Your Modular SIMPLI-FLEX® dispenser is designed to provide an easy means of dispensing. Please clean dispenser before use. Regular cleaning will prolong the life of the dispenser, keep it looking new and ensure sanitary dispensing.

For reference to instructions below use exploded view of cabinet dispenser. (See page 1 Figure 3)

PART 1: Disassemble

1. Remove decorative clamp ring (See Figure 4 illustration A and B).
2. Peel off gasket from lip of dispenser (See Figure 4 illustration C and D).
NOTE: CAUTION when removing gasket, pusher may be under small amount of spring tension.
3. Remove pusher from spring (See Figure 4 illustration E and F).
4. Remove spring from dispenser (See Figure 4 illustration G and H).
5. Using a philips screwdriver loosen screws by turning in a counter-clockwise direction 3 to 4 turns. (See Figure 4 illustration I thru K)
NOTE: It is not necessary to remove screws from cabinet dispenser.
NOTE: CAUTION when reassembling, do not over tighten screws (2 inch pounds maximum).
6. Align eyelet holes with head of screws by rotating dispenser tube in a counter-clockwise direction. (See Figure 4 illustration L thru N)
7. Remove dispenser tube from cabinet by sliding horizontally keeping dispenser tube parallel with cabinet. (See Figure 4 illustration O)

PART 2: Cleaning parts

1. Clean clamp ring and gasket in hot, soapy water. Air dry.
NOTE: these parts are dishwasher safe.
2. Rinse cabinet, dispenser tube, spring, pusher and wipe with a non-toxic cleaner/sanitizer.
3. Reassemble cabinet dispenser in reverse order. (See Figure 4 illustration O thru A)

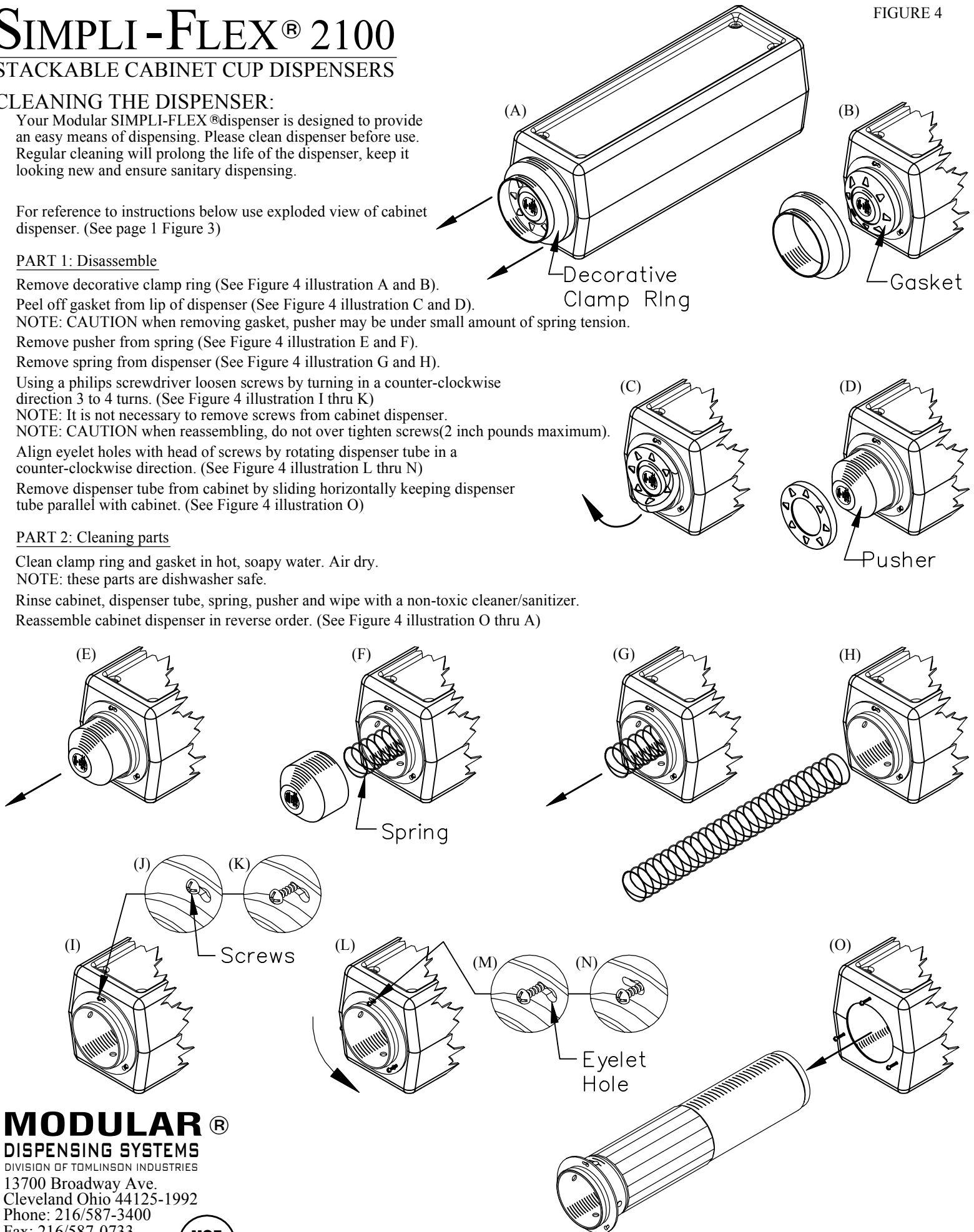

MODULAR®
DISPENSING SYSTEMS
 DIVISION OF TOMLINSON INDUSTRIES
 13700 Broadway Ave.
 Cleveland Ohio 44125-1992
 Phone: 216/587-3400
 Fax: 216/587-0733
 www.tomlinsonind.com



World Class, Worldwide
 ©Tomlinson Industries 1999